

J1 Joey

Combines attributes of elevating work platforms, order pickers and tuggers in a compact and capable vehicle design.

CAPACITY

- 1000 lb (454 kg) combined
 - 500 lb (227 kg) front work platform
 - 300 lb (36 kg) operators compartment
 - 200 lb (91 kg) rear "hide away" tray

BATTERY

- 24-volt battery pack (4) 6V 224 AH AGM maintenance-free batteries
- Built-in 110VAC 15A charger
- Minimum battery weight: 480/590 lb (218/268 kg)
- AH capacity (min/max): 180/255
- Compartment dimensions (open): 26.37" x 8.06"
- Battery compartment rollers
- Connector: SB-175 Gray – A-11

SPEED

- ZAPI AC-0 travel controller
- EPS AC-0 power steering controller with dashboard display
- Variable from 0 mph to 3.4 mph
- Reduced travel speed at elevation

- **LIFT:** up to 42 fpm

WEIGHT

- 2,268 lb (1,029 kg) (chassis only)

TIRES / WHEELS

- **DRIVE:** (1) 9" x 3" polyurethane
- **STABILITY:** (2) 3" x 2" polyurethane
- **LOAD-STEEL HUB:** (2) 8" x 3" polyurethane

ELECTRICAL

- AC controller manages travel, braking, lift/lower, and steering
- LCD dashboard displays hour meter, battery state, travel speed, and travel direction indicator
- AC drive motor
- Low-maintenance brushless design
- Programmable travel speeds, plugging, and neutral braking are infinitely variable
- Low battery travel lockout

BRAKES

- Regenerative braking
- Electromagnetic parking brake



OPERATION / CONTROLS

- Ergonomic fingertip control for travel, lift, and lower functions
- Roomy operator compartment
- Retractable compartment guard rails keep the operator secure
- On/off key switch and horn

MAST

- Heavy-duty I-beam design
- Steel mast channels and side mounted lift cylinders

CHASSIS

- Three-point chassis design
- 180° drive motor

STANDARD EQUIPMENT

- Electronic power steering
- Hide away rear work platform
- Front and rear flashing light

OPTIONAL EQUIPMENT

- Anchor with tether and harness
- High speed travel
- Tow hitch
- Industrial battery and charger

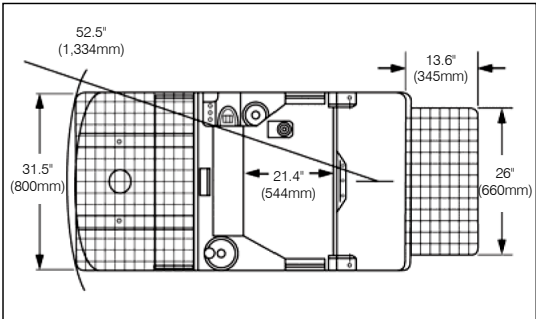
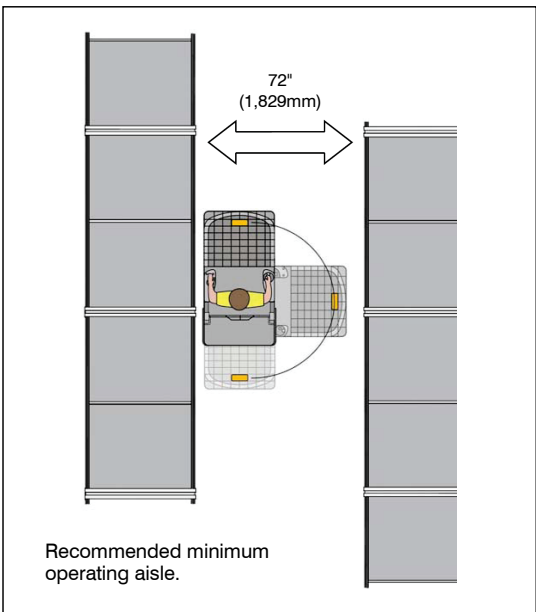
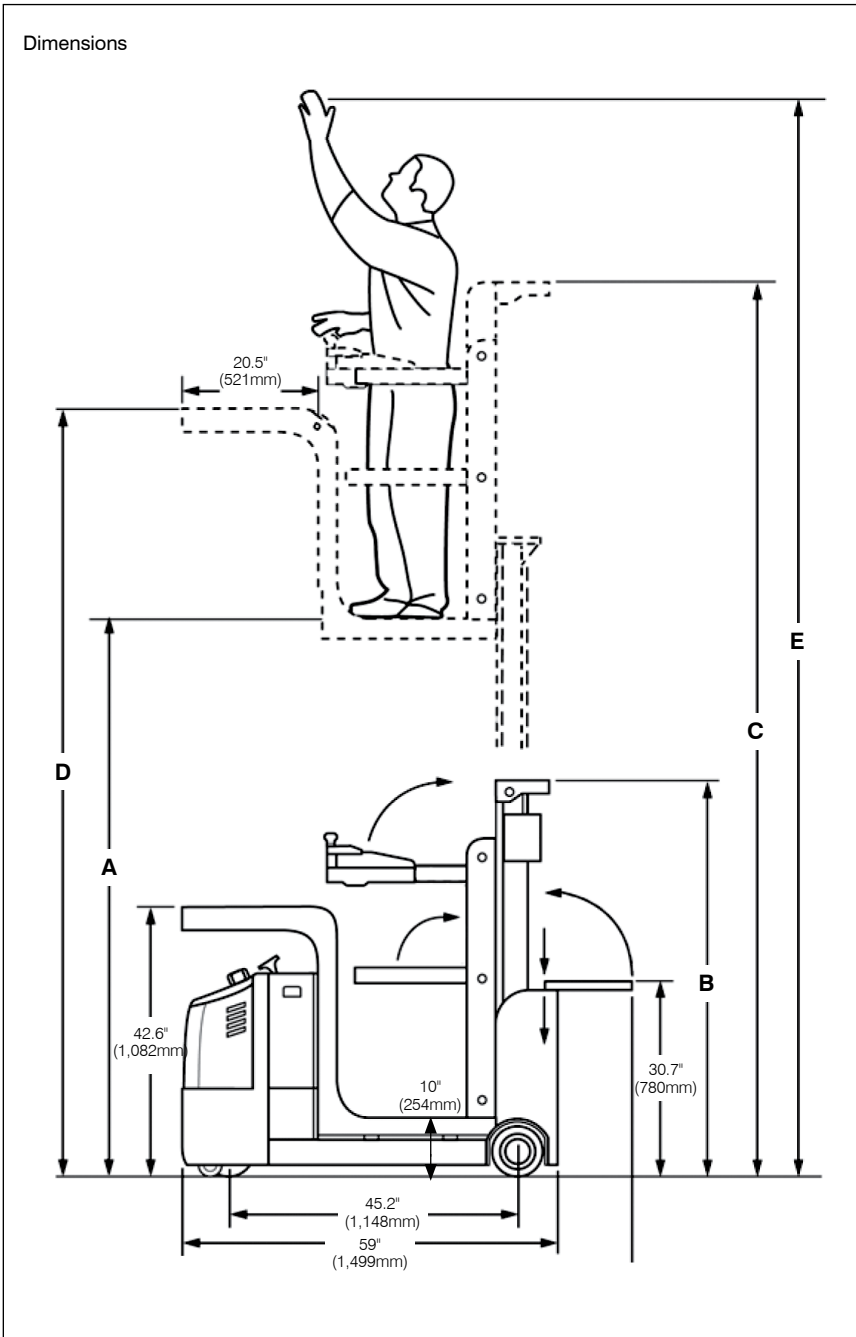

Model#	Mast	Vertical Travel Height		Lowered Mast Height		Extended Height		Load Tray Height		Working Height		Weight (Chassis Only*)	
		A		B		C		D		E			
J1-126	Triple Stage	126"	3,200mm	62.6"	1,590mm	178.6"	4,536mm	168.5"	4,280mm	203"	5,156mm	2,268 lb	1,029 kg
J1-162	Triple Stage	162"	4,115mm	80.5"	2,045mm	214.6"	5,451mm	204.6"	5,197mm	239"	6,071mm	2,610 lb	1,184 kg

* Complete weight includes truck, battery and charger.